

my solution to some discussion problems week 11
 NOV 12 to NOV 18
 ME 240 Dynamics, Fall 2017

Nasser M. Abbasi

December 30, 2019

My solution is below

0.1 Problem 6 3 Example 1

Linkage - Acceleration

Example 5.15: A 3-in. radius drum is rigidly attached to a 5-in. radius drum as shown. The 3-in drum rolls without sliding on the surface shown, and a cord is wound around 5-in. drum. At the instant shown end D of the cord has a velocity of 8 in/s and an acceleration of 30 in/s², both directed to the left

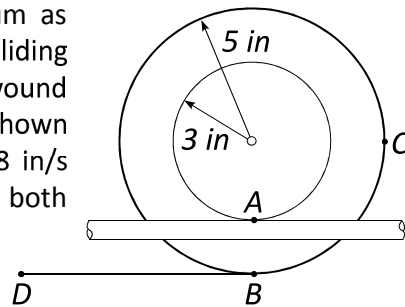

Determine the accelerations of points A , B , and C of the drum.

Given

$$\begin{aligned}\vec{V}_D &= -8\hat{i} \\ \vec{a}_D &= -30\hat{i}\end{aligned}$$

But also (assuming cord is not extensible)

$$\begin{aligned}\vec{V}_B &= -8\hat{i} \\ \vec{a}_B &= -30\hat{i}\end{aligned}$$

Since the point B is also on the large disk, its velocity can be used to find the angular velocity of the disk. The disk is spinning in the clockwise direction. Using $V_B = r\omega_{disk}$, where $r = 5$ inch, then $\omega_{disk} = \frac{-8}{5} = -1.6$ rad/sec or

$$\vec{\omega}_{disk} = -1.6\hat{k}$$

Similarly $a_B = r\alpha_{disk}$ in the clockwise direction, hence $\alpha_{disk} = \frac{a_B}{r} = \frac{-30}{5} = -6$ rad/sec²

$$\vec{\alpha}_{disk} = -6\hat{k}$$

Now

$$\vec{a}_A = \vec{a}_B + \vec{\alpha}_{AB} \times \vec{r}_{A/B} - \omega_{AB}^2 \vec{r}_{A/B}$$

Where $\vec{r}_{A/B} = (r_2 - r_1)\hat{j} = (5 - 3)\hat{j} = 2\hat{j}$ and the above becomes

$$\begin{aligned}\vec{a}_A &= -30\hat{i} + (-6\hat{k} \times 2\hat{j}) - (-1.6)^2 (2\hat{j}) \\ &= -30\hat{i} + (12\hat{i}) - 5.12\hat{j} \\ &= -18\hat{i} - 5.12\hat{j}\end{aligned}$$

Now

$$\vec{a}_C = \vec{a}_O + \vec{\alpha}_{OC} \times \vec{r}_{C/O} - \omega_{OC}^2 \vec{r}_{C/O}$$

Where O is the center of the disk. Since disk is not sliding, then $\vec{a}_O = 0$ and $\vec{r}_{C/O} = 5\hat{i}$. The above becomes

$$\begin{aligned}\vec{a}_C &= -6\hat{k} \times 5\hat{i} - (-1.6)^2 5\hat{i} \\ &= -30\hat{j} - 12.8\hat{i}\end{aligned}$$

0.2 Problem 6 3 Example 2 rev2

Linkage - Acceleration

Example 5.16: The disk at A is subjected to the angular motion (velocity and acceleration) shown.

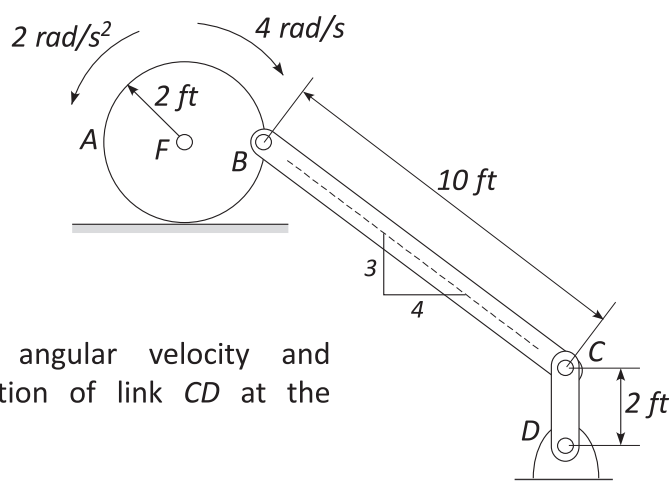

Determine the angular velocity and angular acceleration of link CD at the instant shown.